

Product information

Focusing on
tomorrow, caring
for today

EBD 330

1/3" Day/Night Camera with IR-LED,
high resolution



Specifications

Sensor: 1/3" SONY CCD
Picture element: 752 x 582 (PAL)
Horizontal resolution: 480 TV lines
Sensitivity: 0,5 lux / F = 1.2 (IR-LED off)
IR - LED: 14 x, controlled by internal twilight switch, splitted front glass for low internal IR - reflection
IR - LED lifetime: up to 50.000 h
IR - Range: 5~20m*
Video output: 1 Vp-p composite PAL
S/N ratio: over 48 dB
Gamma correction: 0,45
Synchronisation: internal
Back light compensation: yes
Auto white balance: yes
AGC: yes
Electronic shutter: auto 1:50 ~ 1:100.000

Lens: 4,3 mm / F2 , M12 x P0,5

Mounting: Ceiling or wall, 3-axis adjustment of camera module

Casing: aluminium
Weatherproof rating: IP 66

Power source: 12 V DC +/- 10%
Power consumption: 6 W max.

Ambient temperature: -10°C ~ +50°C
Dimensions: 94 (diam.) x 82 (H) mm

Weight: 450 g

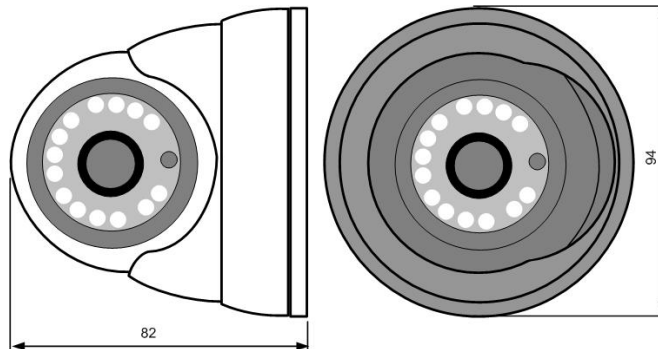

* The IR illumination range depends on the location, particularly with regard to the reflections of the installation's surroundings. Locating the device near highly absorbent surfaces can result in a significantly reduced range.